

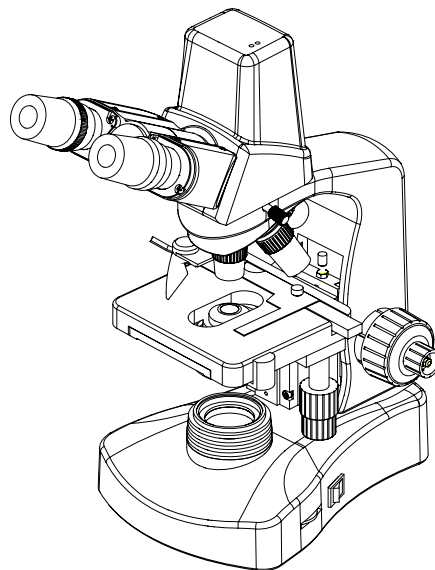

Digital Biological Microscope

Model Number:BS-2020BD

Instruction Manual



This manual is written for digital biological microscope BS-2020BD. To ensure the safety, obtain optimum performance and to familiarize you fully with the use of this microscope, it is recommended strongly that you study this manual thoroughly before using the microscope and retain this manual in an easily accessible place near the work desk for future reference.

CONTENT

User Notice.....	2
1. Components.....	4
2.Assembly.....	5
2.1 Assembly Diagram.....	5
2.2 Assembly Steps.....	6
3.Adjustment & Operation.....	10
3.1 Adjustment Sets.....	10
3.2 Operation.....	11
4. Specification Table.....	14
4.1 Main specifications.....	14
4.2 Eyepieces and Objectives.....	14
4.3 Total Magnification.....	15
5. Outfit.....	15
6. Troubleshooting Guide.....	16

User Notice

I . Safety Notes

1. Carefully open the box, avoid the accessories, like lens, dropping to ground and being damaged.
2. Do keep the instrument out of direct sunlight, high temperature or humidity, dusty and easy shaking environment. Make sure the stage is smooth, horizontal and firm enough.
3. When moving the instrument, please use two hands to grip with the two sides of the microscope body.
4. When running, the lamp house and nearby parts will be very hot. Please ensure there is enough cooling room for them.
5. Make sure the instrument is earthed, to avoid lightning strike.
6. For safety, be sure the main switch is in “O”(off) state before replacing the halogen lamp or the fuse, then cut off the power, and do the operation after the lamp bulb and the lamp house completely cool down.(**Specified: Halogen Lamp 6V/20W or LED 3W**)
7. Check the input voltage: be sure the input voltage which signed in the back of the microscope is consistent with the power supply voltage, or it will bring a serious damage to the instrument.
8. Use the factory supplied power cord, please.

II. Maintenance

1. All the lenses have been well checked and adjusted. It is forbidden to disassemble them yourself.
2. The nosepiece and coarse/fine focus unit have a compact and precise frame; please don't disassemble them as possibly as you can.
3. Keep the instrument clean, wipe dust regularly, and be attention to avoid contaminating the optical elements especially.
4. The contaminations on the prism, as finger mark and oil, could be gently wiped with a piece of soft cloth or tissue paper, gauze which has been immersed in pure alcohol or aether. (**Note that the alcohol and ether are highly flammable, do keep them away from the fire or potential sources of electrical sparks, and use them in a drafty room as possible as you can.**)
5. Do not attempt to use organic solvents to clean the microscope components other than the glass components. To clean them, use a lint-free, soft cloth slightly moistened with a diluted neutral detergent.
6. When using, if the microscope is splashed by liquid, cut off the power at once, and wipe up the moisture.

7. Do not disassemble any parts of the microscope, which will affect the function or decline the performance of the microscope.
8. Place the instrument in a cool, dry position. When not using the microscope, keep it covered with a dust cover. Make sure the lamp socket is cool before covering the microscope.

1. Components

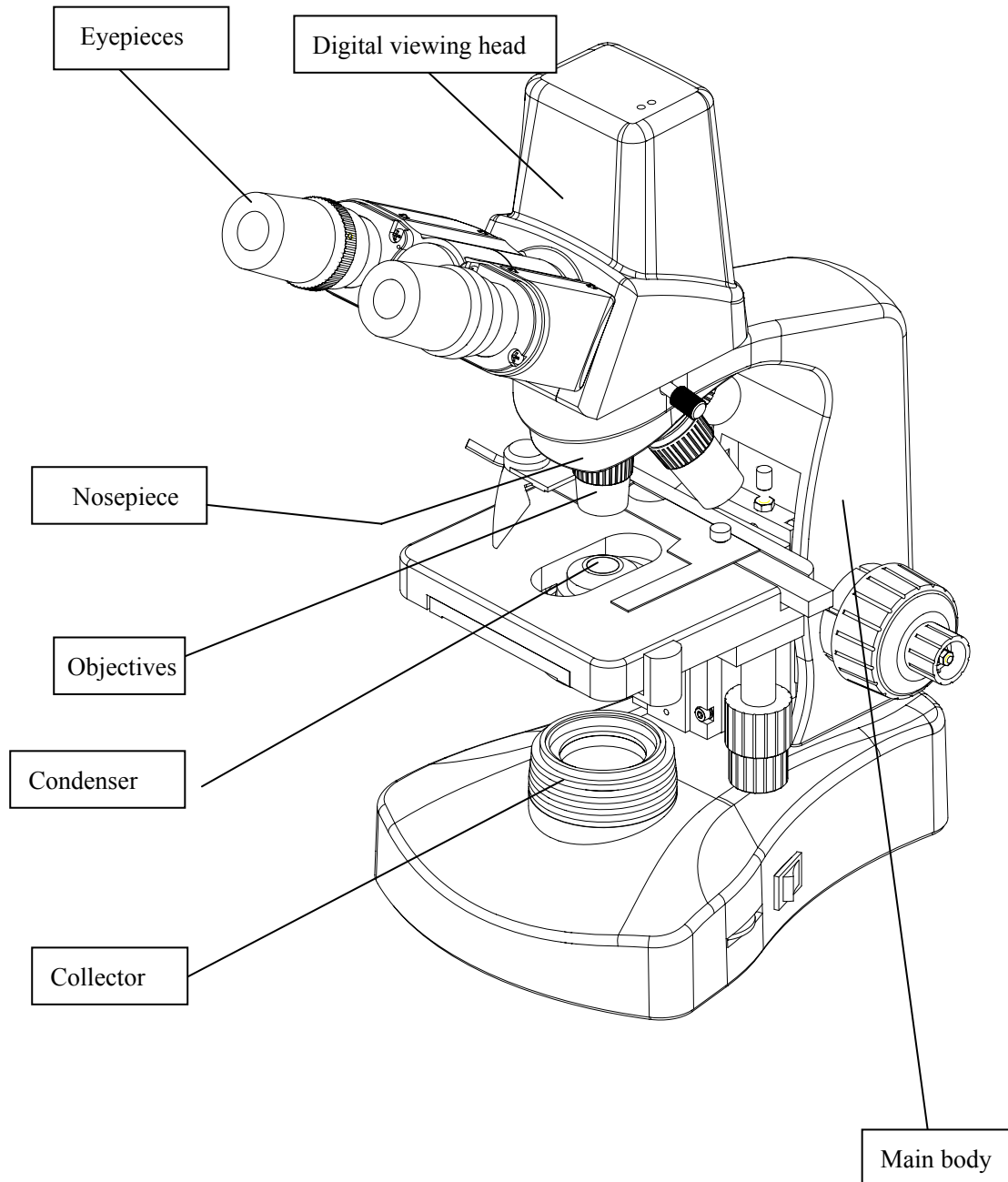

BS-2020BD Digital Biological Microscope

2.Assembly

2.1 Assembly Diagram

The following figure shows the installation sequence of the components. The number in the figure shows the assembly steps.

- ★ Before installing, be sure every components is clean, do not score any parts or glass surface.
- ★ Keep well with hexagon wrench provided. When replacing the components, you will need it again.

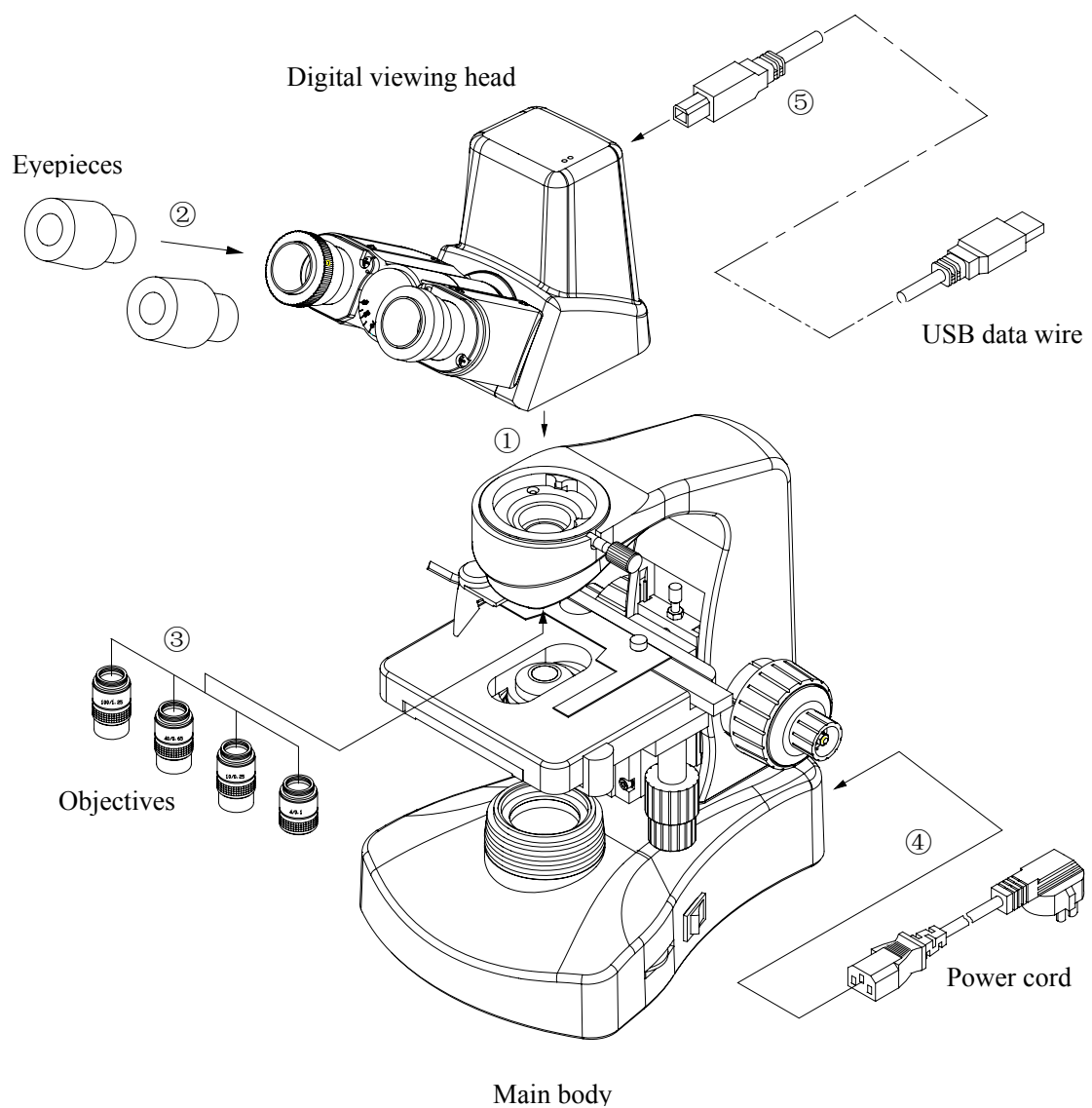

2.2 Assembly Steps

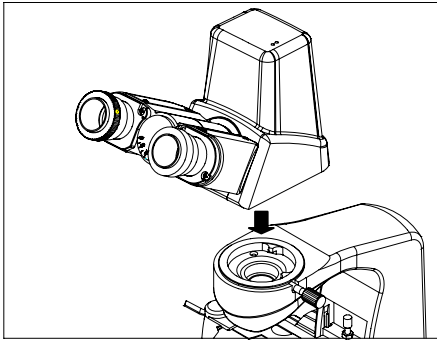

Fig.1

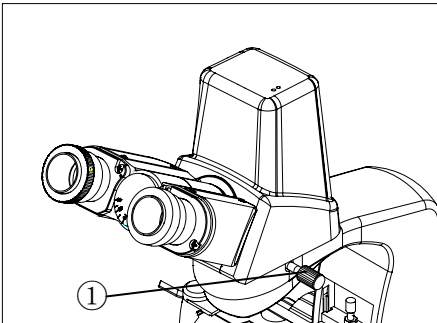

Fig.2

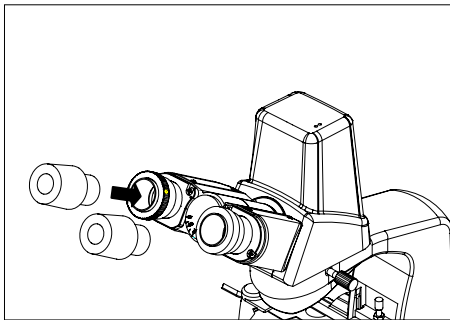

Fig.3

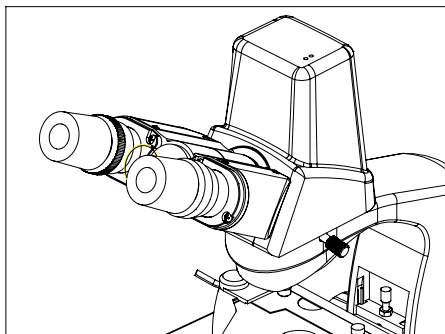

Fig.4

2.2.1 Installing digital viewing head (Fig.1、 2)

Insert the digital viewing head into the microscope head, turn into the right position, then screw down the bolt①to fix it.

2.2.2 Installing the eyepieces (Fig.3、 Fig.4)

Insert the eyepieces into the eyepiece tube until they are against each other as shown in Fig.4.

NOTE:

Operation Conditions:

1. Temperature: 0 °C ~ 40 °C ,Maximum Relative Humidity: 85%.
2. High Temperature: High Temperature and humidity will result in a mildewing, dew and even ruinous instrument.
3. Avoid placing the instrument in a dusty environment. When ending your microscope operation, please cover it with the dust cap.
4. Lay the microscope in a plan and stable position, please.

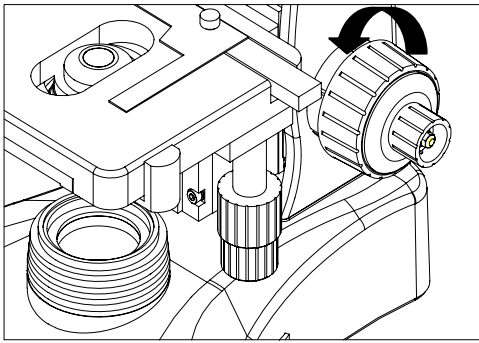

Fig.5

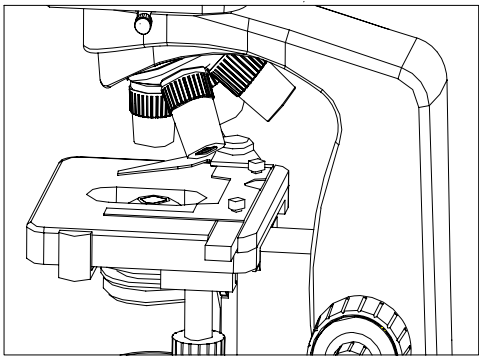

Fig.6

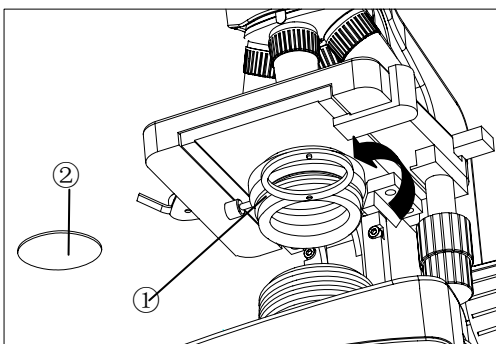

Fig.7

2.2.3 Installing objectives (Fig.5& 6)

1. Adjusting the coarse focus knob until the support device of the mechanical stage reaches its low limit position.
2. Screw the lowest magnification objective into the nosepiece from the left or the right side, then revolve the nosepiece clockwise and mount other objectives by the sequence of low to high magnification

◇ Installing objective this way will make the change of magnification to be easier during using.

★ Clean the objectives regularly, for lens is susceptible to dust.

★ When operating, use 10× magnification objective to search and focus specimen firstly, then replace with higher magnification objective if necessary.

★ When replacing the objective, slowly turn the nosepiece until you hear “clicked”, which means the objective is in the required position—center of the light path.

2.2.4 Installing the color filters (Fig.7)

1. Turn the condenser bracket① out at the direction of arrow in Fig.7
2. Put the required filters② into the holder on the bracket, and then turn the bracket back to the right position.

★ Baby blue and green filters are available in standard outfit.

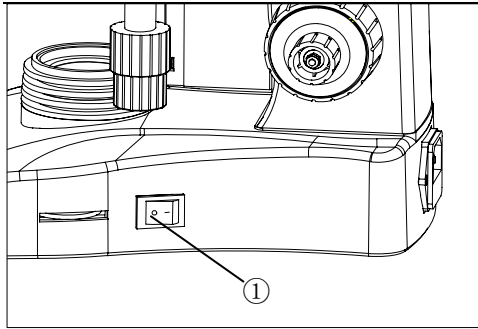

Fig.8

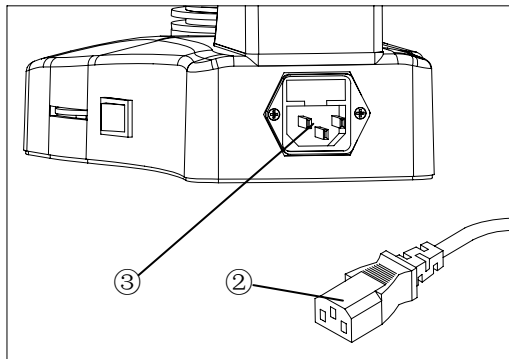

Fig.9

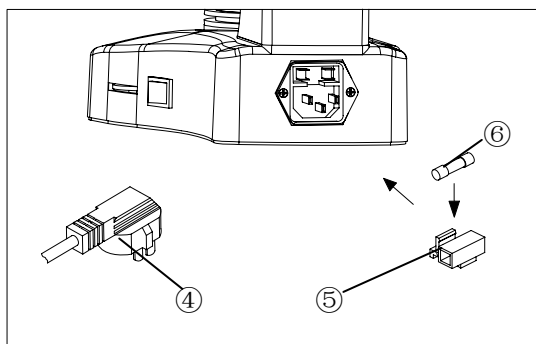

Fig.10

2.2.5 Connecting the power cord (Fig.8, 9,10)

★ The cable and cords are vulnerable when bent or twisted, never subject the power cord to excessive force.

1. Turn the main switch① to “O” (off) state before connecting the power cord.
2. Insert the power plugs② into the power jack③ of the microscope; make sure the connection is well.
3. Plug the power cord ④ into the power supply receptacle safely. Make sure the connection is well.

★ Do use the supplied power cord all the time. If it lost or damaged, select the same standard cord, please.

★ Either 110V or 220V can be selected as the input voltage of this microscope. (The input voltage has been preset in the microscope before leaving factory.

2.2.6 Replacing the Fuse (Fig.8、 9、 10)

Do remember to set the main switch① to the state of “O” (OFF) and unplug the power cord ② before replacing the fuse. Scratch the fuse holder⑤ out from the power socket③ on the microscope, replace with a new fuse in the holder, then press the fuse holder back again.

★ There is a spare fuse in the fuse holder.

★ For 220V input voltage, use fuse of rating (250V500mA).

★ For 110V input voltage, use fuse of rating (250V1A).

2.2.7 Installing and replacing the lamp (Fig.11,12,13)

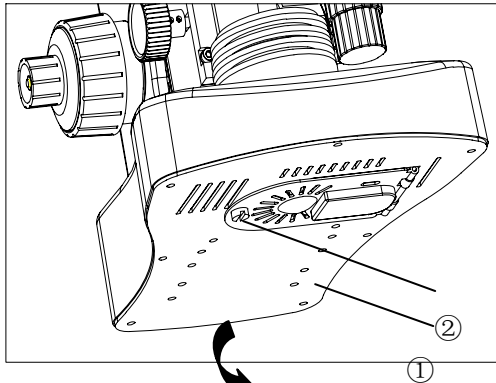

Fig.11

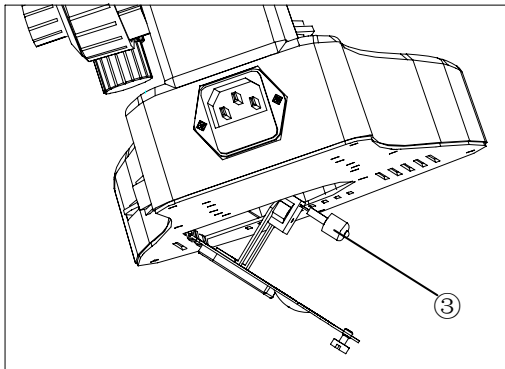

Fig.12

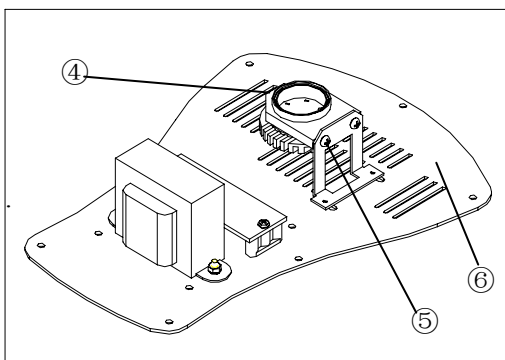

Fig.13

✧ There are two types of illuminator available for this microscope, one type is halogen lamp 6V20W, the other is 3W LED. During use or just after using, the lamp house and nearby parts will be very hot. Please set the main switch to “O” (off) state before replacing, and make sure the bulb, the lamp room and periphery are all cool enough to carry no burn. Then, you can do your replacing.

1. Loose the bolt①and open the window② on the bottom of the microscope base with “—”type screwdriver.
2. Pull out the old bulb③ ,hold the new bulb after you wrap it with gauze or other protection materials and insert its pin as deeply as possible into the jack in the lamp holder.
4. Close the window and tighten the bolt①.
★ Please insert the bulb gently, or it will be damaged by excessive extrusion.

★ Do not touch the halogen bulb with bare hands. It will shorten the service life or cause it to burst. If you leave fingerprints on the surface carelessly, clean it with a piece of dry soft cloth.

When replacing LED :

1. Generally, the LED has long service life and is not easy to damage, if unfortunately it damaged, purchase a new one from the supplier.
2. Remove the base plate⑥ from the bottom side of the microscope base with screw driver ,loose the bolt⑤ to take the old LED off, replace with a new one .
3. Put the new LED unit back onto the bracket with the bolt⑤ and the base plate⑥ onto the bottom side of the microscope.

✧When you take down the base plate, please do it gently and slowly, to avoid damaging internal electrical wires.

3. Adjustment & Operation

3.1 Adjustment Sets (Fig.14, Fig.15)

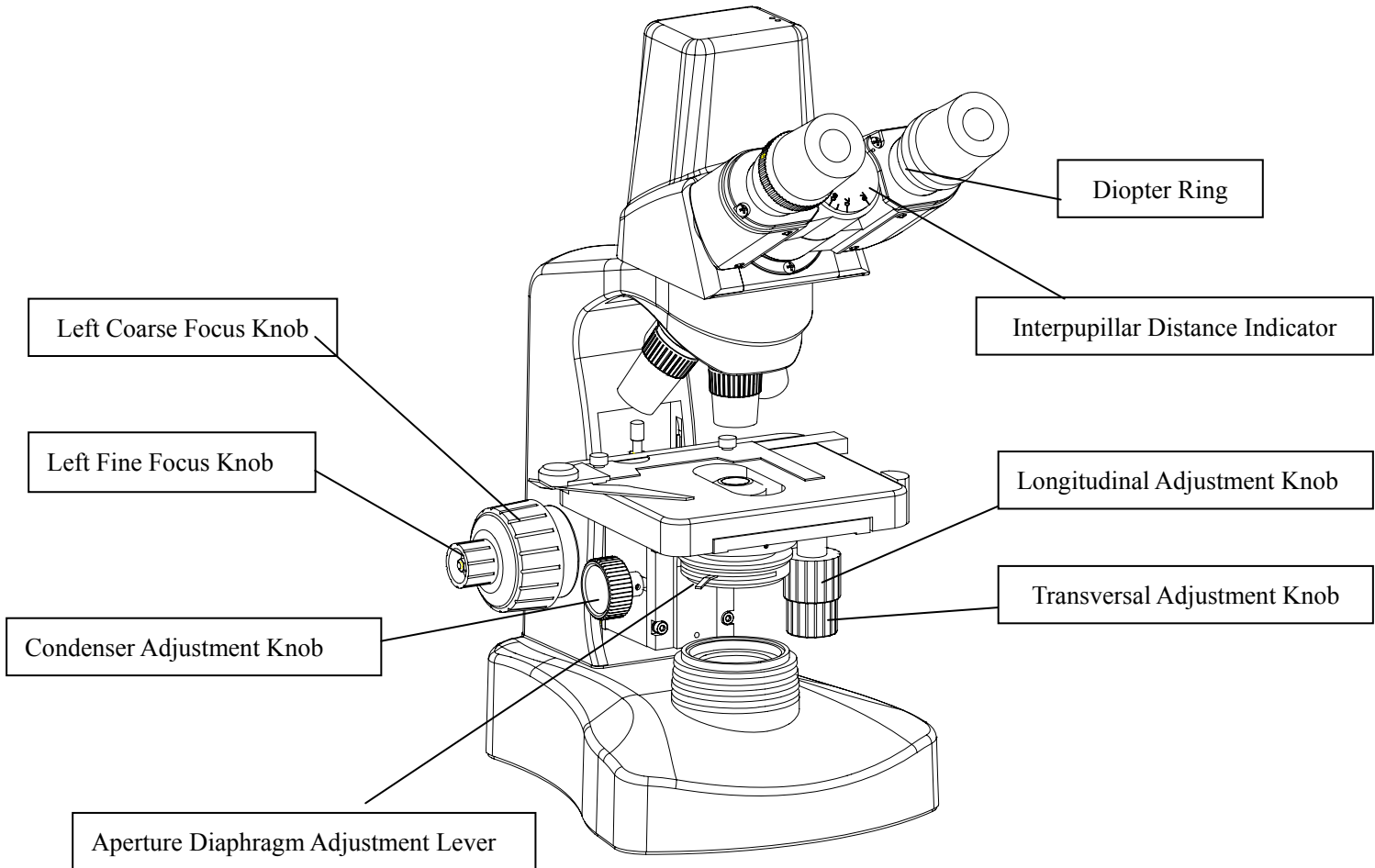
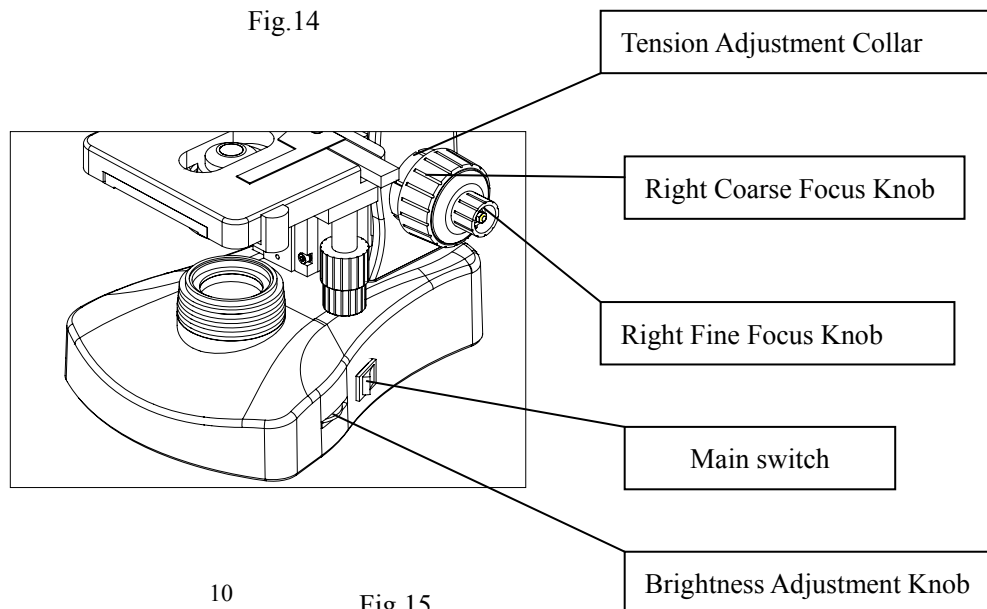

Fig.14



3.2 Operation

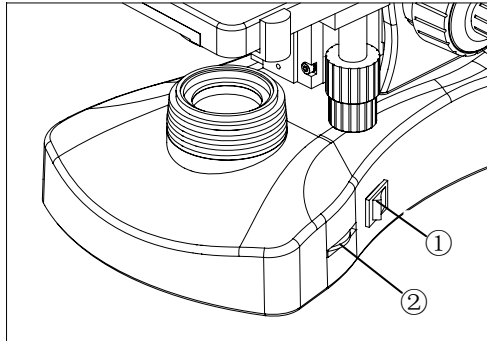

Fig.16

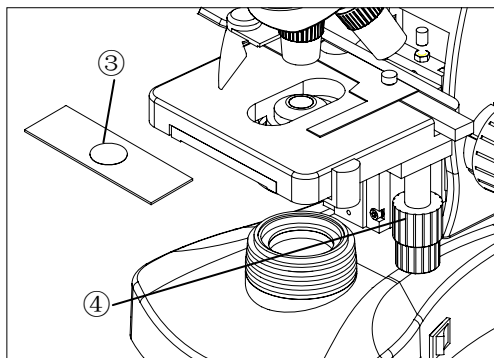

Fig.17

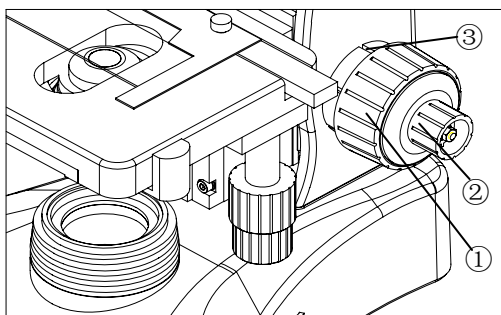

Fig.18

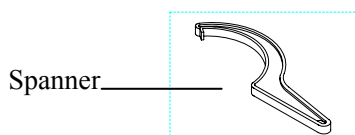

Fig.19

3.2.1 Adjusting the brightness (Fig.16)

1. Connect the power, turn on the main switch①(shown in the figure)which on the bottom side of the base to “—”(on).
2. Turning the brightness adjustment knob ② clockwise, the voltage decline, and the brightness weaken; Whereas turning at the opposite direction, the voltage raise, and the brightness strengthen.

★ Using the microscope at a lower voltage can prolong the service life of the bulb.

3.2.2 Placing the specimen (Fig.17)

1. Place the specimen③ on the center of the stage, and then hold it with the specimen holder④.
2. Turn the transversal and longitudinal adjustment knobs which on the mechanical ruler to move the specimen onto the required position.

★ Be careful when changing the objective. If you finish the observation with the short working distance objective, and want to change another one, be careful of not letting the objective touch the specimen.

3.3.3 Focusing the specimen(Fig.18、 19)

1. Focus the specimen with 10X objective. To avoid the objective touching the specimen during focusing, you should raise the mechanical stage to let the specimen close to the objective at first, then slowly dispart them to bring the specimen to focus.
2. Turn the coarse focus knob ①conversely to lower the specimen and search images in the 10×ocular simultaneously, and then use the fine knob② to make focus. After that, you can replace with other magnification objectives safely, and focus without the risk of damaging the specimen.

- The tight tension of the coarse focus knob has already been adjusted before leaving factory. If loosen (e.g. the stage slip down by its weight), please screw the intention adjustment collar③ to the right position by the supplied spanner.

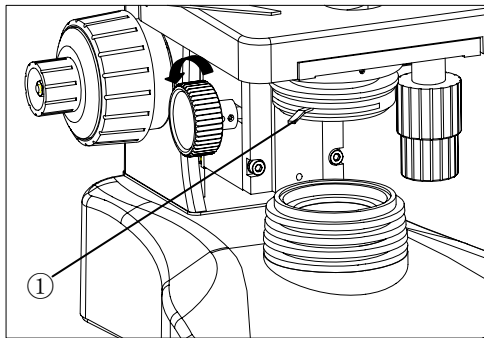

Fig.20

3.3.4 Condenser Adjustment (Fig.20)

Turn the condenser focus knob to move the condenser up and down. Raise the condenser when using the high magnification objective, and descend it when using the low magnification one.

- ★ The condenser and the objective are coaxial. It has been adjusted well before leaving factory, so the user needn't to adjust them by self (the distance between the top of the condenser and the stage should be in the range of 0.03mm~0.4mm.)
- ★ The highest position of the condenser has been adjusted too. It also needn't any user's operation.

3.3.5 Aperture Iris Diaphragm Adjustment (Fig.20,21)

Turn the aperture iris diaphragm lever ① to adjust the aperture iris diaphragm.

- Generally, setting the aperture iris diaphragm to 70- 80% of the N.A. of the objective in use will provide an image with good contrast.
- If the size of the aperture diaphragm minified, the brightness and the resolution declined, while the contrast and the depth of field increased; In other words, if the size largen, the brightness and the resolution improved, but the contrast and the depth of field declined.
- Generally, setting the size of the condenser aperture diaphragm at 70%~80% of the numerical aperture, you can obtain a clear image with enough contrast. If the open of the aperture diaphragm is too small, the resolution were very low, so please don't minify the aperture below 60% of the objective's numerical aperture unless in a special case, for instance, observing an almost transparent specimen.

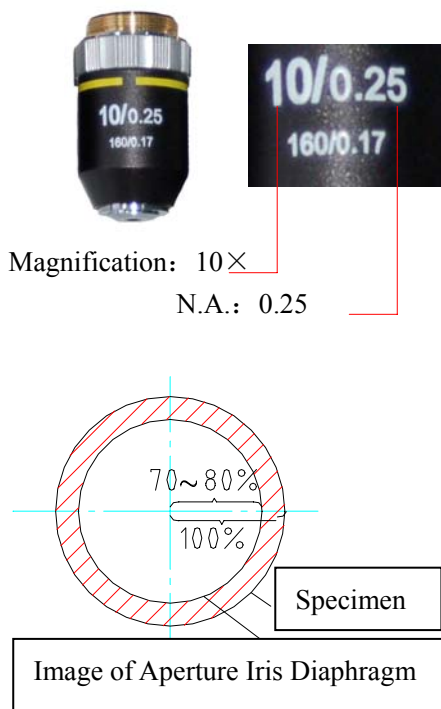

Fig.21

- The numerical aperture is marked on the objective. For example, the mark “ 10/0.25 ” means the magnification is 10×, and the numerical aperture is 0.25.
- If you want to observe the image of the aperture iris diaphragm, remove one eyepiece and look through the tube. You will see a dark circle encroaching on the bottom of the tube.

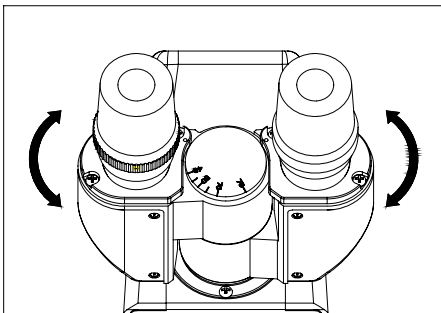

Fig.22

3.3.6 Adjusting the Interpupillary Distance (Fig.22)

The interpupillary distance range:

48mm~75mm。

When observing with two eyes, hold on the left and right prism holders, turn them around the axis to adjust the interpupillary distance until the left and right fields of view coincide completely, as shown in Fig.22.

3.3.7 Adjusting the diopter (Fig.23)

1. Looking through the right ocular with your right eye, revolve the coarse and fine focusing adjustment knob to focus on the specimen.
2. Then look through the left ocular with your left eye. If the image is not sharp, turn only the left diopter adjustment ring① to focus on the specimen please.

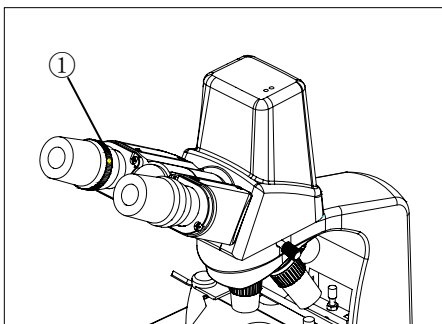

Fig.23

★ The diopter range of the eyepiece is ± 5 diopter. The number aligned to the line on the viewing head is the diopter in use.

4. Specification Table

4.1 Main specifications

Mechanical Tube Length	160mm
Viewing Head	Compensation free binocular head, , Inclined at 30°,Interpupillary Distance 48-75 mm
Eyepiece	Field of view: ϕ 18mm
Nosepiece	Backward Quadruple Nosepiece
Objective	Achromatic objectives 4 \times , 10 \times , 40 \times 、100 \times
Focusing	Coaxial coarse and fine focusing knob; the minimum division of fine focusing:0.004mm; focusing adjustment range: 24mm
Condenser	Abbe Condenser, NA=1.2 with iris diaphragm
Stage	Double Layers Mechanical Stage 132mm \times 142mm, Moving Range 74 \times 40mm
Illumination	Halogen Lamp 6V20W or LED 3W

4.2 Eyepieces and Objectives

1. Objectives

Magnification	Numerical Aperture (NA)	Thickness of glass slide (mm)	Focal length (mm)	Working Distance (mm)	Type
4 \times	0.10	0.17	31.05	18	Dry
10 \times	0.25	0.17	17.13	6.5	Dry
40 \times	0.65	0.17	4.65	0.53	Dry
100 \times	1.25	0.17	2.906	0.13	Oil

2. Eyepieces

Category	Magnification	Focal length f (mm)	Field of view (mm)
Plan eyepiece	10 \times	24.95	Φ 18

4.3 Total Magnification

Eyepiece	10×	10×	10×	10×
Objective	4×	10×	40×	100×
Total Magnification	40×	100×	400×	1000×

5. Outfit

Component Name	Specification	Quantity	Standard Outfit
Main body	Main Standard	1	○
	Double Layers Mechanical Stage	1	○
	Condenser Holder	1	○
Viewing Head	Compensation free digital binocular head	1	○
	USB data wire(2 meters)	1	○
Condenser	Abbe condenser for bright field with iris diaphragm NA=1.2	1	○
Nosepiece	Quadruple	1	○
Illumination	Halogen Lamp 6V20W (or LED 3W)	1	○
	Spare lamp (6V20W Halogen lamp)	2	○
	Spare fuse (50T250V2A or 500mA)	1	○
Eyepieces	10×Plan Eyepieces	2	○
Objectives	Achromatic objective 4×	1	○
	Achromatic objective 10×	1	○
	Achromatic objective 40×	1	○
	Achromatic objective 100× (oil、spring)	1	○
Filter	Baby Blue, Green	1 ea.	○

6. Troubleshooting Guide

1. Optical system

TROUBLE	CAUSE	SOLUTION
The edge of the field of view is dark or the brightness is not uniform	The nosepiece is not in the located position (objective and light path not coaxial)	Locate the nosepiece properly where it clicks
	The image of filament is not centered	Center the filament
	A lens (the objective, condenser, eyepiece or collector) is dirty.	Clean it thoroughly
Find dust and stain in the field of view	There are stains on the lens (including condenser, objective, eyepiece and collector)	Clean it up
	There are stains on the specimen	Clean it up
	The position of the condenser is too low	Loosen the condenser's locking bolt, adjust the condenser to the right position
The image is defocused (low resolution \ contrast)	There is no cover slip on the specimen	Add coverslip
	The cover slip is too thick or too thin	Use the standard coverslip (0.17mm)
	The specimen is placed inversely	Reversal it back
	There was oil on the dry objective(easily happened in 40X objective)	Clean it up
	There are stains on the lens (including condenser, objective, eyepiece and collector)	Clean it up
	didn't use oil for the oil objective	Use immerse oil
	There was bleb in the oil	Eliminate the bleb
	Use a unsuitable oil	Change to the specified one
	The size of the aperture diaphragm is too big	Minify it
	There are stains on the incident lens of the binocular tube	Clean it up
	The size of the aperture diaphragm is too small	Open it up
The position of the condenser is too low	Adjust the position	
One side of the image is dark	The condenser is not in the center of the field of view\the condenser inclines	Install the condenser again and adjust the center carefully by centering the bolt
	The nosepiece is not in the right position	Turning it until it reach the "clicked" position
	The specimen is floating	Fix it
	The specimen slips on the stage	Fix it

The image shift during focusing	The nosepiece is not in the right position	Turn it to the “ clicked ”position
The image is a little yellow	Not use the blue color filter	Use the blue filter
The brightness is not enough	The size of the aperture diaphragm is too small	Adjust again
	The position of the condenser is too low	Adjust the position
	There are stains on the lens (including condenser, objective, eyepiece and collector)	Clean it up

2. Mechanical system

TROUBLE	CAUSE	SOLUTION
The image can not focus when using high magnification objective	The specimen is placed inversely The coverslip is too thick	Turn inversely Use the standard coverslip (0.17 mm)
The objective touch the specimen when changed from low magnification to the higher magnification	The specimen is placed inversely The coverslip is too thick	Turn inversely Use the standard coverslip (0.17 mm)
The specimen is not easy to move	The specimen holder is not fixed	Fix it
The binocular image is not coincident	The interpupillar distance is not correct	Adjust it
Eyes are too tired	No diopter adjustment	Adjust the diopter correctly
	The brightness is not suitable	Adjust the voltage of the lamp

3. Electrical system

TROUBLE	CAUSE	SOLUTION
The lamp can't light when the switch is turned on	No power	Check the connection of the power cord
	The bulb is not inserted	Insert it correctly
	The bulb burns out	Replace it
The lamp burns out suddenly	Use a substandard lamp The voltage is too high	Use the specified lamp to replace, if the problem is not solved, contact with the service department
The brightness is not enough	Use a substandard lamp The voltage is too low	Use the specified lamp increase the voltage



BestScope International Limited

The bulb flickers or the brightness is vertiginous	The bulb is going to burn out	Replace it
	The bulb is not entirely inserted into the holder	Check and insert it again